

QuietDoor

r a y m o n d e m c



QuietDoor

Raymond EMC Quiet**Doors** feature high shielding effectiveness, smooth operation and low maintenance requirements. Innovations that are incorporated into each Quiet**Door** include forward mounted fingerstock, safe and secure latching hardware, easily serviceable components.

Features:

- Easy Operation Only 10 lb Force!
- Forward Mounted Clip-on Fingerstock
- Extremely Low Maintenance
- Optional Finishes
- Custom Sizes
- Door Swing Changeable on Site
- Safe and Clean Internal Latch Mechanism
- 2 Year Warranty

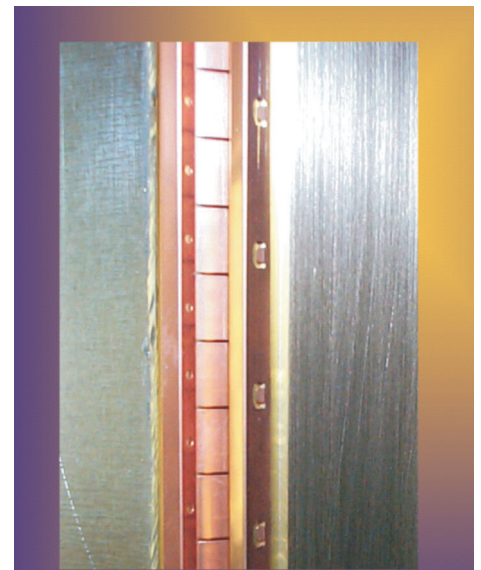

Forward Fingerstock

www.raymondemc.ca

800-EMC-1495 / 613-841-1663 Ottawa, Canada

QuietDoor

raymond emc

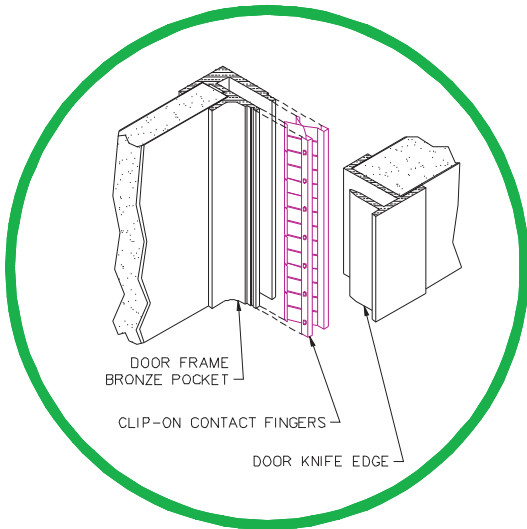

Forward Mounted Fingerstock

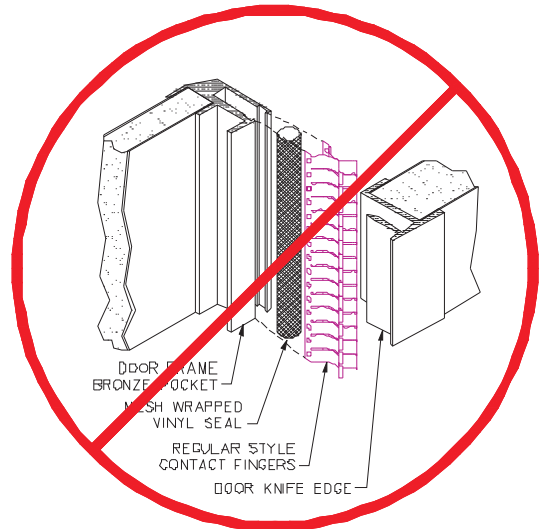

Fingerstock on Older Style Doors

QuietDoors utilizes an extruded bronze pocket that is designed to receive fingerstock, which is mounted forward. The fingerstock is held in place with lances, eliminating the gasket. Forward mounted fingerstock allows QuietDoors to latch smoothly due to the extremely low frictional forces. Less friction not only results in easier operation but also means less wear and tear on the fingerstock and bronze knife-edge, extending the door life and drastically reducing maintenance costs.

On older style doors, the fingerstock is mounted backwards in an extruded bronze pocket and is held in place with a mesh-clad foam gasket. When the door is being latched, the fingerstock is forced backwards as the bronze knife-edge compresses it. This reverse action causes high frictional forces and leads to stiff latching operation and lower fingerstock life. Over time the door gasket becomes saturated with lubricant and attracts debris, increasing wear and decreasing the shielding integrity of the door.

RF Shielding Effectiveness with IEEE-299 Method of Test

Frequency Range	Field Type	QuietDoor Standard (dB)	QuietDoor Extended Range (dB)
1kHz	Magnetic		20
10kHz	Magnetic	55	65
200kHz	Magnetic	95	105
1 MHz-30 Mhz	Magnetic	100	110
10kHz-200 kHz	Electric	100	105
200 kHz-60MHz	Electric	100	120
60 MHz-10 GHz	Planewave	100	120
10 GHz-40 GHz	Planewave		100

QuietDoor

r a y m o n d e m c



DESCRIPTION

High performance low maintenance Quiet**Doors** are manufactured by Raymond EMC, a Canadian manufacturer with over 15 years of experience designing, fabricating and testing standard and custom Radio Frequency Shielded enclosures and components

The door units are factory assembled, consisting of door leaf, door frame, threshold, hardware and electrical contact strips. The door and frame perimeter are bounded with extruded architectural bronze channels. The extruded channel of the frame has a recess to receive two rows of electrical contact strips in such a way that they snap in place without solder or fasteners. The contact strips are unexposed when the door is open and are easily replaceable without tools.

Door hardware consists of: Two thrust and radial bearing hinges with provisions to position the door in frame to the tolerance of 0.005" in both the vertical and horizontal directions. The latching device consists of cam actuated type latch and is operable from both sides of the door. Contact with the strike is by a cam roller bearing. With the door leaf at rest and with the fingerstock in light contact with the knife-edge, the latching mechanism can throw the door into its final closing RFI tight position.



A 12' x 14' Single leaf Quiet**Door** being loaded onto a low bed trailer for delivery

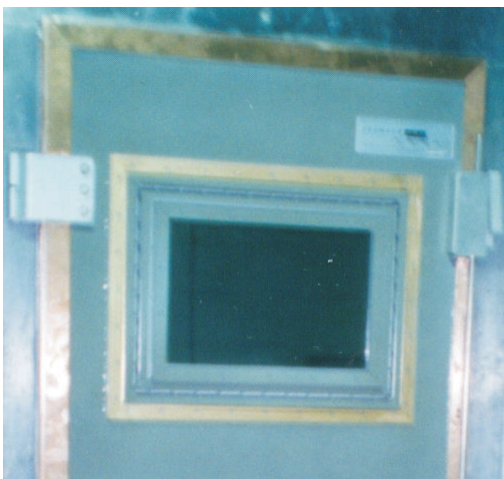

Optional Shielded Window

LIMITED WARRANTY

The Raymond EMC Quiet**Door** is guaranteed against defective materials and workmanship and will retain the specified RF shielding performance for a period of two years from the date of acceptance test, provided that maintenance is performed in accordance with Raymond EMC maintenance procedures.

QuietDoor

r a y m o n d e m c



Raymond EMC offers the QuietDoor with many options and configurations as described below

OPTIONS

- Extended Performance see ratings above
- Door swing is changeable on site (3x7 and 4x7 doors)
- All door swings are available, see chart below
- Standard finish: Galvanized, see colour chart
- Doors are available as either “clamp-in” for modular shields or “weld-in” for welded shields
- Windows are available, however the shielding performance is lowered to 80 dB at 10 GHz
- A phenolic door handle is offered for doors being installed in an Anechoic Chamber

DOOR SIZES

- Doors are available as single or double leaf. A double door has an active and inactive leaf. The active leaf operates as a standard door. The inactive leaf can only be opened after the active leaf is opened.
- Standard Single door sizes:
3' W x 7' H and 4' W x 7' H
- Custom Single door sizes available from:
2' W x 2' H to 14' W x 14' H
- Standard Double door size:
6' W x 7' H
- Custom Double door sizes available from:
6' W x 6' H to 28' W x 28' H

THRESHOLDS

- Standard: 2-3/4" step-over threshold
- Low profile: 1-1/4" high threshold
- Flush: 3/4" tapered threshold for wheel chair accessibility. RF Shielding Effectiveness is reduced to 80dB at 10 GHz.

LATCH STYLE

- **Manual:** the user unlatches the door by pulling upward on the door handle. Once the door is unlatched, the user swings the door open manually; after the user crosses the threshold and releases the door, the hydraulic closer returns the door to the latch position. The user then latches the door by pushing the handle downward.
- **Emergency Exit:** the user unlatches the door by pressing downwards on the Red door handle. Once the door is unlatched, the user swings the door open manually. The door remains open until the user manually swings it closed and latches it by pulling upward on the handle.
- **Semi-automatic:** The user presses the open button and a pneumatic cylinder unlatches the door. Once the door is unlatched, the user manually swings the door open. After the user crosses the threshold and releases the door, a hydraulic closer returns the door to the latch position and the pneumatic cylinder latches the door. Compressed air (60psi) is required on site.
- **Fully-automatic:** The user presses the open button and a pneumatic cylinder unlatches the door. Once the door is unlatched, an overhead electric opener then swings the door open. After the user has crossed the threshold and cleared the safety mats, the opener swings the door closed and the pneumatic cylinder latches the door. Compressed air (60psi) is required on site.

DOOR SWING CHART

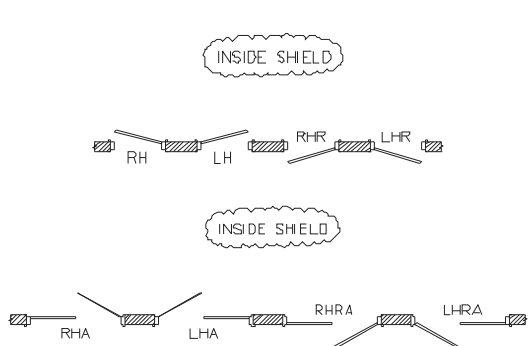

RH and LH indicate Right and Left Hand “swing in”.

RHR and LHR indicate Right and Left Hand Reverse “swing out”.

The suffix “A” on double doors designates the hand and swing of the active leaf.

COLOUR CHART



Galvanized



Black



Grey

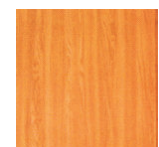

Wood Grain